



**Internationales Fahrturnier  
International Driving Event  
CAI 3\*/CAI 2\*  
Nationales Fahrturnier  
CAN  
20.04.-23.04.2023**

**Liebe Teilnehmer/innen,  
Herzlich Willkommen zum diesjährigen Fahrturnier  
beim  
„Fahr - und Reitverein Wettringen“.  
Getreu unserem Motto  
„Turnier von Fahrern für Fahrer“  
wünschen wir Euch viel Erfolg und vor Allem viel  
Spaß!**

# **Teilnehmerunterlagen**

**CAN KI. A**

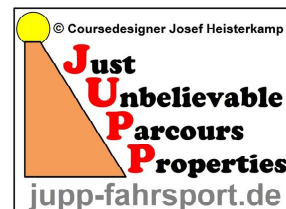



**Internationales Fahrturnier  
International Driving Event CAI 3\*/CAI 2\*  
Nationales Fahrturnier CAN  
20.04.-23.04.2023**

**Section A for all  
classes  
Aufwärmstrecke für  
alle Klassen**

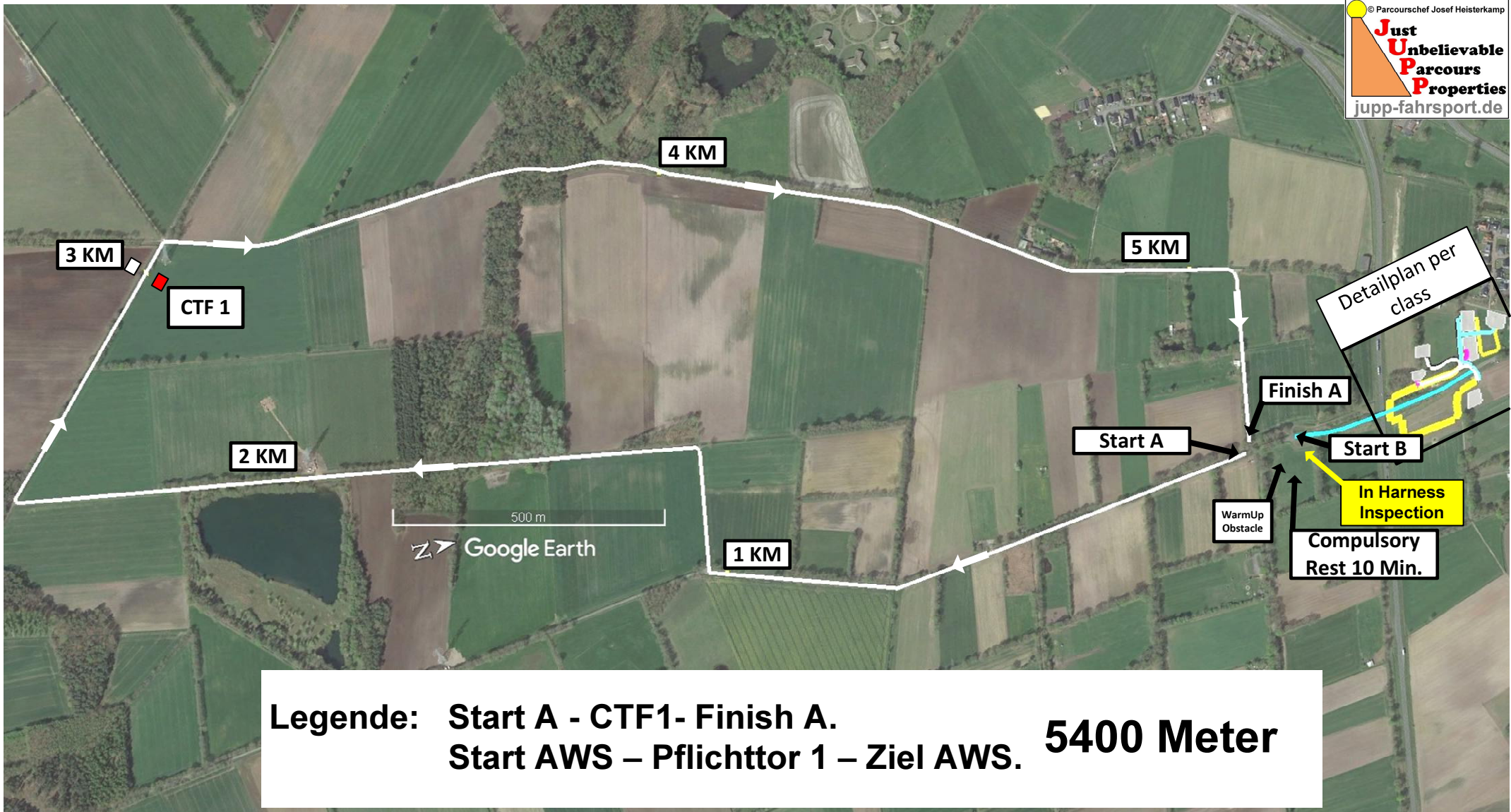



# Internationales Fahrturnier International Driving Event CAI 3\*/CAI 2\* Nationales Fahrturnier CAN

20.04.-23.04.2023

**HS KI. A**  
(Hindernisstrecke)  
**3845 Meter**

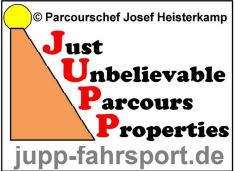

**Pflichttore**  
**2 - 9**

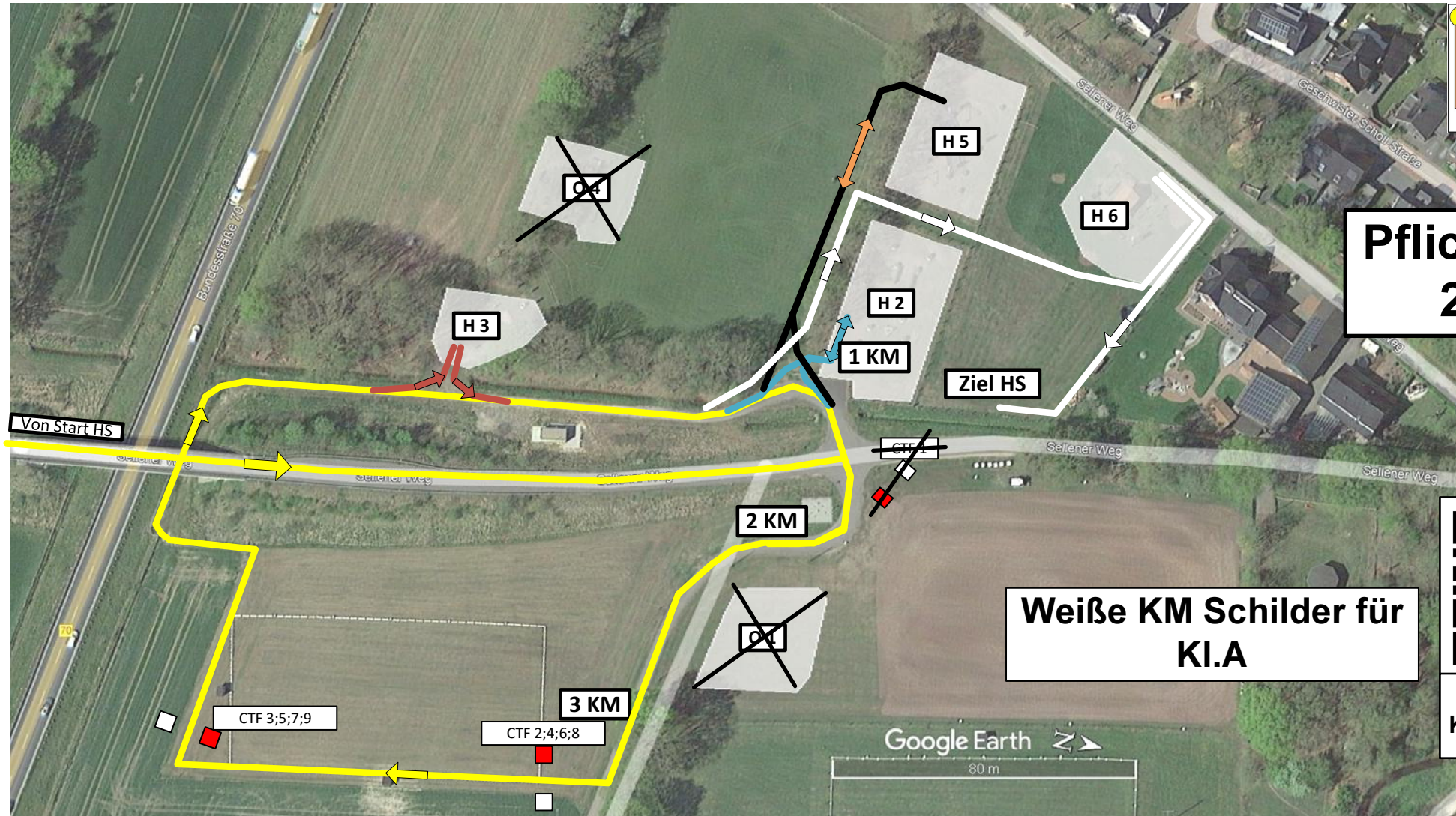

**Weißer KM Schilder für  
KI.A**



Downloadlink  
KI.A Geländeunterlagen

Legende: Start HS / CTF2 / CTF3 / **H2** / 1KM / CTF4 / CTF5 / **H3** / 2KM / CTF6 / CTF7 / **H5** / 3KM / CTF8 / CTF9 / **H6** / Ziel HS. 3845 Meter



# Times Marathon Geländezeiten

CAI 3* H1 HORSES	Length in Meter	Tempo KM/h	Minimum Time h:min:sec	Time allowed h:min:sec	Maximum Time h:min:sec	Compulsory Turning Flags
Section A	5400	13	00:22:55	00:24:55	00:29:54	CTF 1
REST				00:10:00		
Section B	5290	14	00:19:40	00:22:40	00:45:21	CTF 1-11
Cool Down	Area		00:10:00		00:15:00	
CAI 3* P1 PONYS	Länge in Meter	Tempo KM/h	Minimum Time h:min:sec	Time allowed h:min:sec	Maximum Time h:min:sec	Compulsory Turning Flags/ Pflichttore
Section A	5400	12	00:25:00	00:27:00	00:32:24	CTF 1
REST				00:10:00		
Section B	5290	13	00:21:25	00:24:25	00:48:50	CTF 1-11
Cool Down	Area		00:10:00		00:15:00	
CAI 2* H1 HORSES	Länge in Meter	Tempo KM/h	Minimum Time h:min:sec	Time allowed h:min:sec	Maximum Time h:min:sec	Compulsory Turning Flags/ Pflichttore
Section A	5400	12	00:25:00	00:27:00	00:32:24	CTF 1
REST				00:10:00		
Section B	5000	13	00:20:05	00:23:05	00:46:09	CTF 2-11
Cool Down	Area		00:10:00		00:15:00	
CAI 2* P1 PONYS	Länge in Meter	Tempo KM/h	Minimum Time h:min:sec	Time allowed h:min:sec	Maximum Time h:min:sec	Compulsory Turning Flags/ Pflichttore
Section A	5400	11	00:27:27	00:29:27	00:35:21	CTF 1
REST				00:10:00		
Section B	5000	12	00:22:00	00:25:00	00:50:00	CTF 2-11
Cool Down	Area		00:10:00		00:15:00	
Klasse A national PFERDE	Länge in Meter	Tempo KM/h	Minimum Time h:min:sec	Time allowed h:min:sec	Maximum Time h:min:sec	Compulsory Turning Flags/ Pflichttore
Aufwärmstrecke	5400	11,5	00:26:10	00:28:10	00:33:49	CTF 1
Zwangspause				00:10:00		
Hindernisstrecke	3845	12,5	00:15:27	00:18:27	00:36:55	CTF 2-9
Klasse A national PONYS	Länge in Meter	Tempo KM/h	Minimum Time h:min:sec	Time allowed h:min:sec	Maximum Time h:min:sec	Compulsory Turning Flags/ Pflichttore
Aufwärmstrecke	5400	11	00:27:27	00:29:27	00:35:21	CTF 1
Zwangspause				00:10:00		
Hindernisstrecke	3845	12	00:16:14	00:19:14	00:38:27	CTF 2-9



Internationales Fahrturnier  
International Driving Event  
CAI 3\*/CAI 2\*  
Nationales Fahrturnier  
CAN  
20.04.-23.04.2023

**H**indernis  
**O**bstacle **2**

Powered by:



# Wall

Geländefahren Kl. A  
Prfg.Nr: 19;23;27;31;35 und 36 nur  
**Tore A-D**

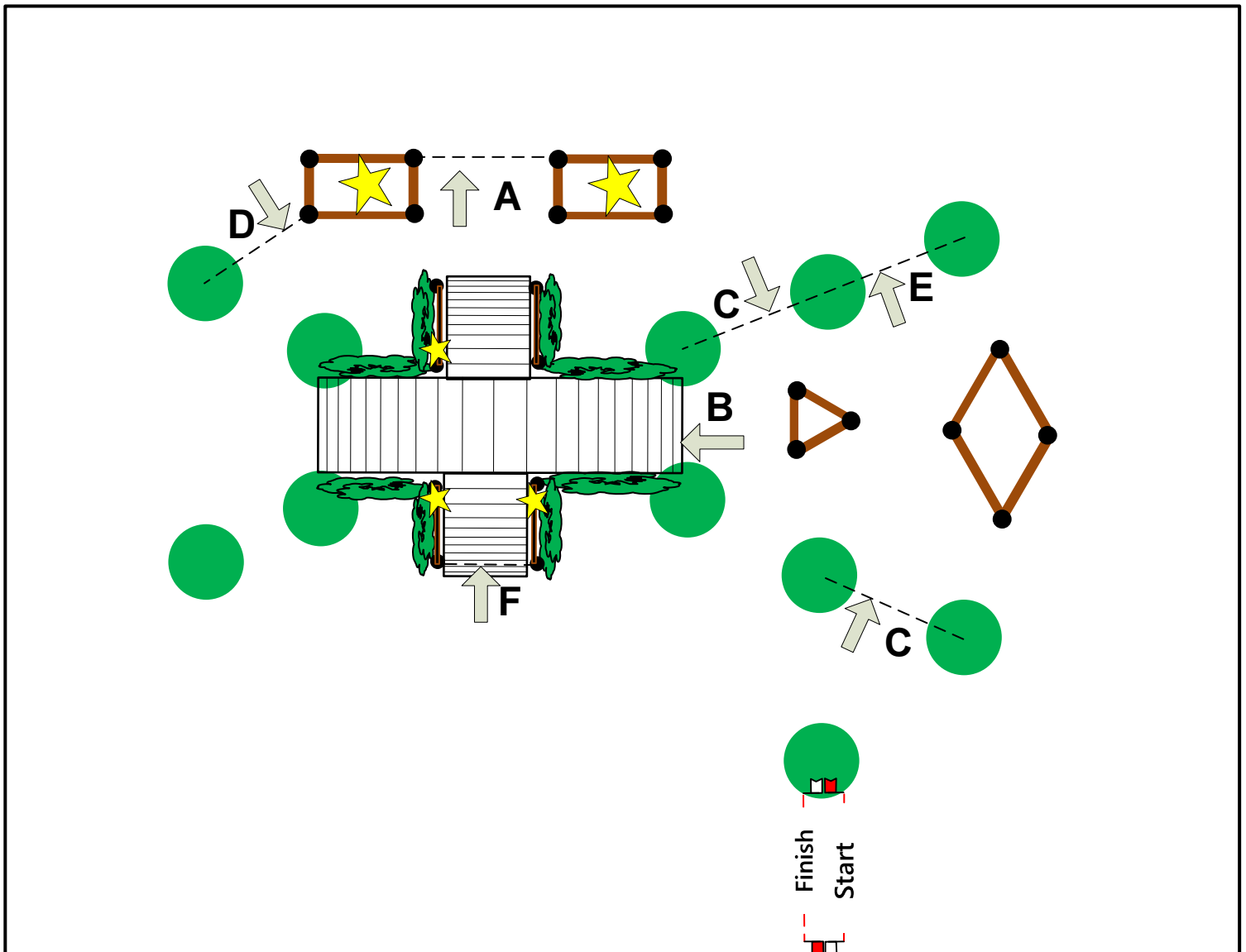

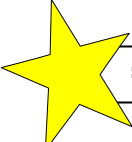
 = 5 Knock Down



Internationales Fahrturnier  
International Driving Event  
CAI 3\*/CAI 2\*  
Nationales Fahrturnier  
CAN  
20.04.-23.04.2023

**H**indernis **3**  
**O**bstacle

Powered by:



**Menzel's  
Wassergraben**

Geländefahren Kl. A

Prfg.Nr: 19;23;27;31;35 und 36 nur

**Tore A-D**

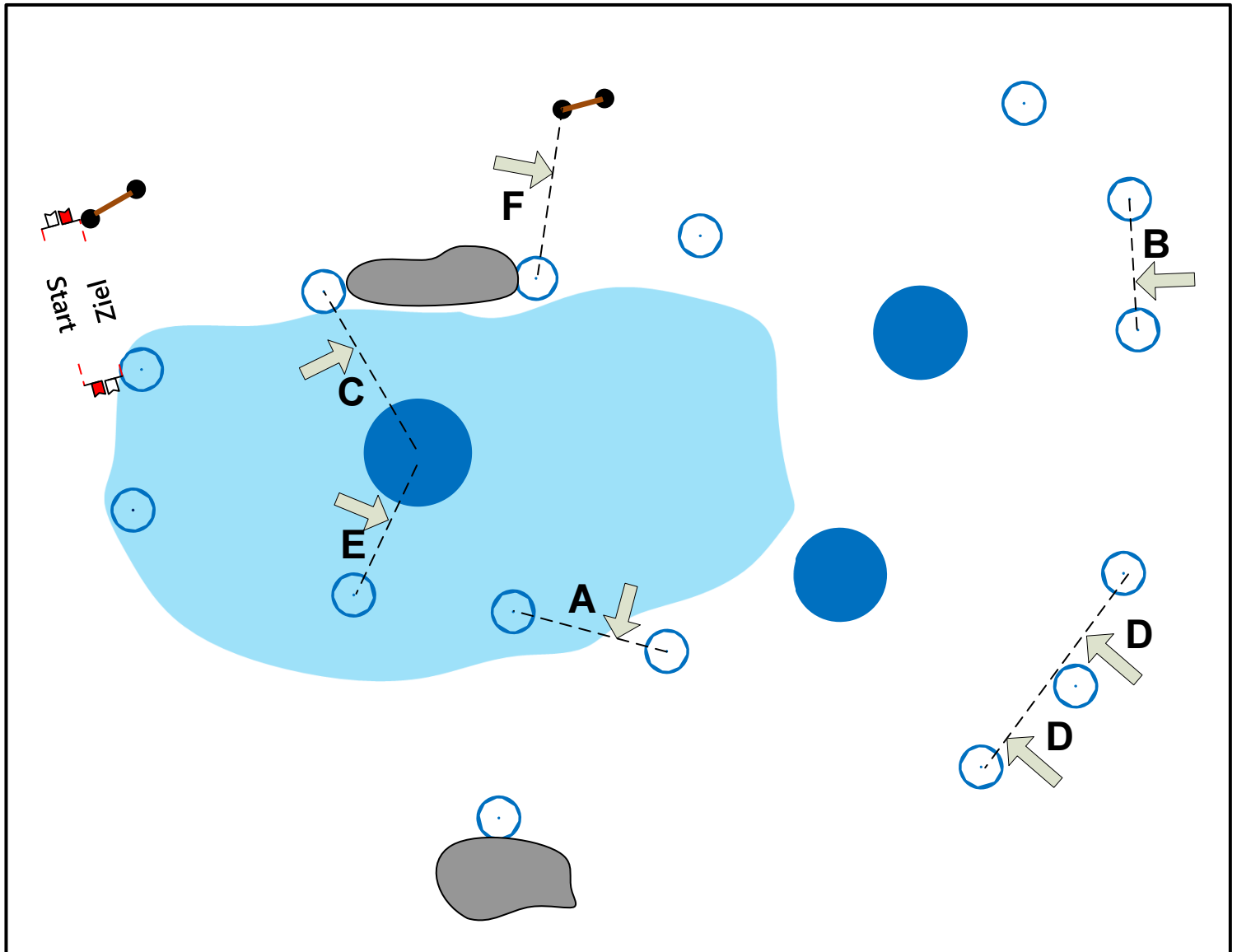



Internationales Fahrturnier  
International Driving Event  
CAI 3\*/CAI 2\*  
Nationales Fahrturnier  
CAN  
20.04.-23.04.2023

**H**indernis  
**O**bstacle **5**

Powered by:



## Elektro Brinner Brücke

Geländefahren Kl. A

Prfg.Nr: 19;23;27;31;35 und 36 nur

**Tore A-D**

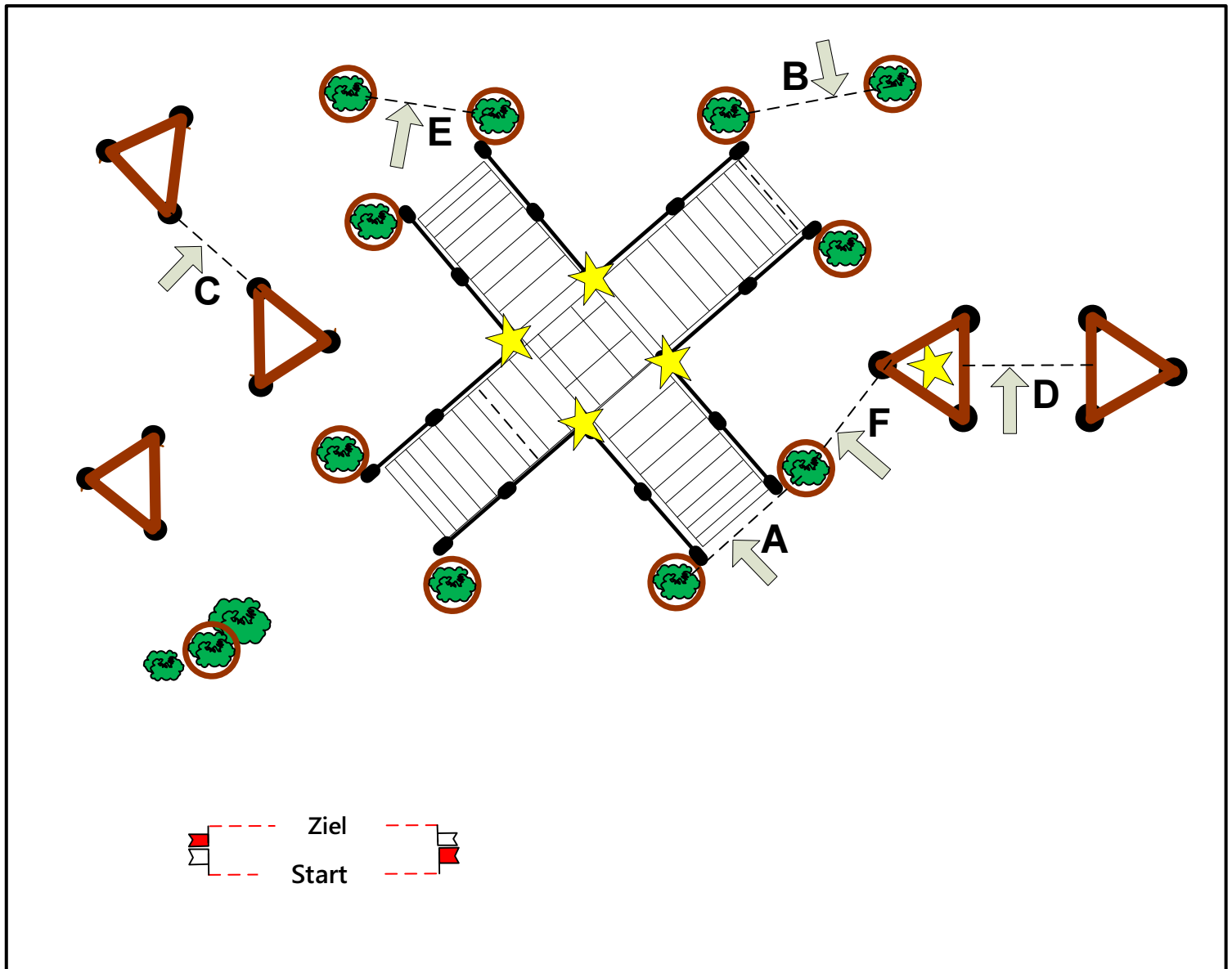

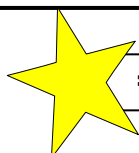
 = 5 Knock Down



Internationales Fahrturnier  
International Driving Event  
CAI 3\*/CAI 2\*  
Nationales Fahrturnier  
CAN  
20.04.-23.04.2023

**H**indernis  
**O**bstacle **6**

Powered by:



Hüsches  
PS Schuppen

Geländefahren Kl. A  
Prfg.Nr: 19;23;27;31;35 und 36 nur

**Tore A-D**

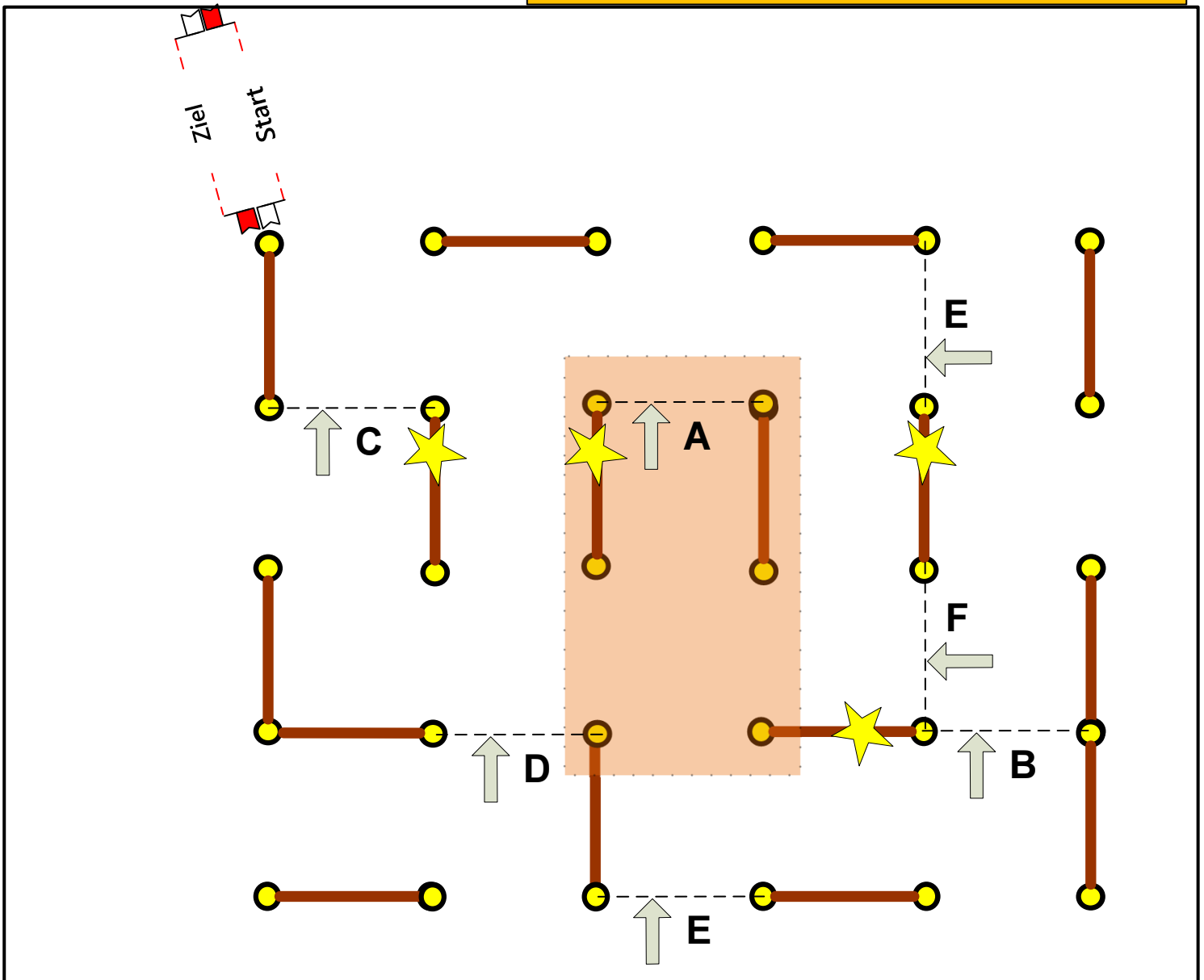

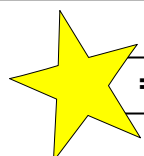
 = 4 Knock Down